

Características

- Los orificios pasantes en el cuerpo permiten un montaje simple.
- Cuerpo fabricado con aluminio anodizado de alta resistencia que proporciona una gran resistencia a la corrosión
- Disponible con sensores.
- Magnético como estándar.

Ejemplo de pedido

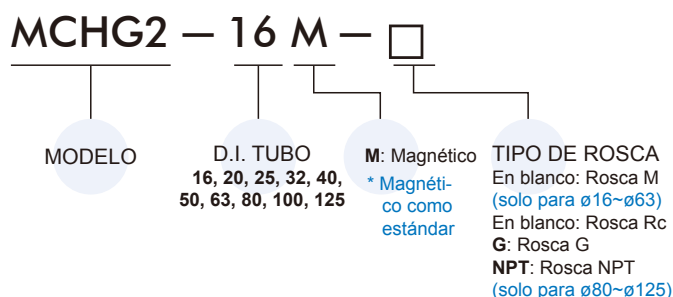

Especificaciones

Modelo	MCHG2										
Tipo de acción	Doble efecto										
D.I. Tubo (mm)	16	20	25	32	40	50	63	80	100	125	
Carrera (mm)	4	4	6	8	8	12	16	20	24	32	
Tamaño del puerto	M3×0.5	M5×0.8					Rc1/8	Rc1/4	Rc3/8		
Media	Aire										
Presión de funcionamiento (MPa)	0.2~0.6					0.1~0.6					
Temperatura ambiente	-10~+60°C (Sin congelación)										
Repetibilidad	±0.01 mm										
Frecuencia operativa máx. (c.p.m)	120					60			30		
Lubricación	No requerido										
Fuerza de agarre efectiva N (lbf) a (0.5 MPa) (*)	Externo	14(3.1)	25(5.6)	42(9.4)	74(16.6)	118(26.5)	187(42)	335(75)	500(112)	750(169)	1270(285)
	Interno	16(3.6)	28(6.3)	47(10.6)	82(18.4)	130(29)	204(46)	359(81)	525(118)	780(175)	1320(297)
Sensor final de carrera	2 cables	RDFE(V): Sin contacto (Consulte la página 5-10)									
	3 cables	RNFE(V): NPN, RPFE(V): PNP									
Peso (g)	80	110	150	240	400	540	1020	1880	3300	6200	

* Los valores de diámetro abierto y cerrado se aplican para el agarre externo de piezas de trabajo.

Instalación

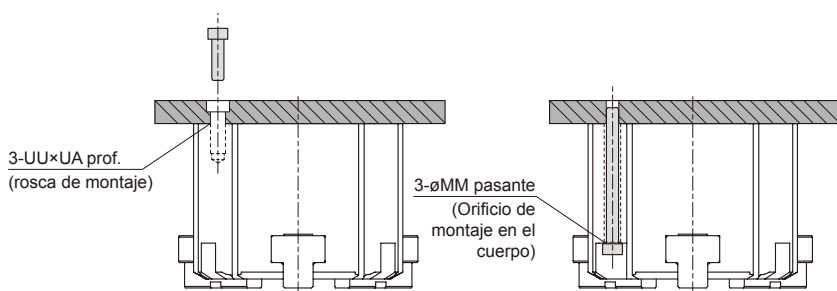

Modelo	MM	UU×UA	Tornillo
MCHG2-16	3.4	M3×0.5×4.5	M3×0.5
MCHG2-20	3.4	M3×0.5×6	M3×0.5
MCHG2-25	4.5	M4×0.7×6	M4×0.7
MCHG2-32	4.5	M4×0.7×6	M4×0.7
MCHG2-40	5.5	M5×0.8×7.5	M5×0.8
MCHG2-50	5.5	M5×0.8×10	M5×0.8
MCHG2-63	6.6	M6×1.0×9	M6×1.0
MCHG2-80	6.6	M6×1.0×12	M6×1.0
MCHG2-100	9	M8×1.25×16	M8×1.25
MCHG2-125	11	M10×1.5×20	M10×1.5

PINZA PARALELA (3-Dedos)

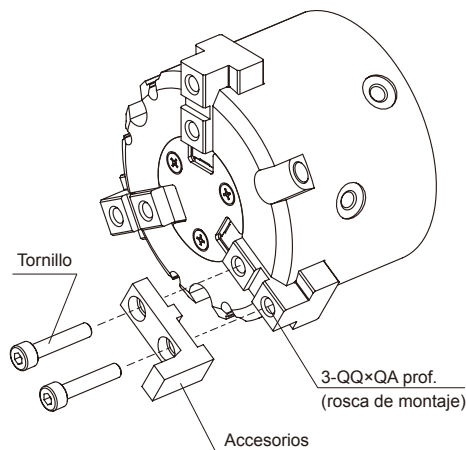
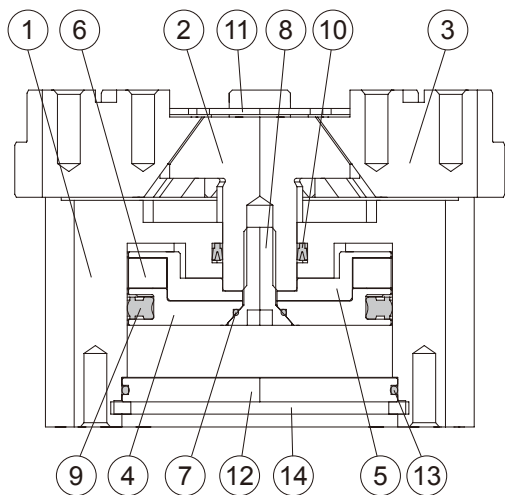

Material

Núm.	Nombre de la pieza	Material	Kits de reparación (incluidos)
1	Cuerpo	Aleación de aluminio	
2	Palanca	Acero al carbono	
3	Patín	Acero al carbono	
4	Pistón	Aleación de aluminio	
5	Pistón R	Aleación de aluminio	
6	Anillo magnético	Material magnético	
7	Junta tórica	NBR	●
8	Tornillo del pistón	Acero al carbono	
9	Juntas del pistón	NBR	●
10	Juntas del vástago	NBR	●
11	Mesa	Acero inoxidable	
12	Placa final	Aleación de aluminio	
13	Junta tórica	NBR	●
14	Anillo elástico	Acero al carbono	

Precauciones de montaje

Consulte la tabla siguiente para ver el par de apriete de los tornillos de montaje del patín.

Modelo	QQ×QA	Tornillo	Par de apriete máx. (N.m)
MCHG2-16	M3×0.5×5	M3×0.5	0.59
MCHG2-20	M3×0.5×6	M3×0.5	0.59
MCHG2-25	M3×0.5×6	M3×0.5	0.59
MCHG2-32	M4×0.7×8	M4×0.7	1.4
MCHG2-40	M4×0.7×8	M4×0.7	1.4
MCHG2-50	M5×0.8×8	M5×0.8	2.8
MCHG2-63	M5×0.8×8	M5×0.8	2.8
MCHG2-80	M6×1.0×12	M6×1.0	4.8
MCHG2-100	M8×1.25×16	M8×1.25	12
MCHG2-125	M10×1.5×20	M10×1.5	24

Ejemplo de pedido de kits de reparación

D.I. Tubo	Kits de reparación	D.I. Tubo	Kits de reparación
ø16	PS-MCHG2-16	ø63	PS-MCHG2-63
ø20	PS-MCHG2-20	ø80	PS-MCHG2-80
ø25	PS-MCHG2-25	ø100	PS-MCHG2-100
ø32	PS-MCHG2-32	ø125	PS-MCHG2-125
ø40	PS-MCHG2-40		
ø50	PS-MCHG2-50		

Fuerza de agarre efectiva

* Para la selección de dedos consulte la pág. 3-2.

Indicador de la fuerza de agarre efectiva.

La fuerza efectiva de agarre que se muestra en los gráficos a la derecha se expresa como F, que es el empuje de un dedo cuando los tres dedos y los adaptadores están en pleno contacto con la pieza de trabajo, como se muestra en la figura a continuación.

1N=0.102 kgf
1MPa=10.2 kgf/cm²

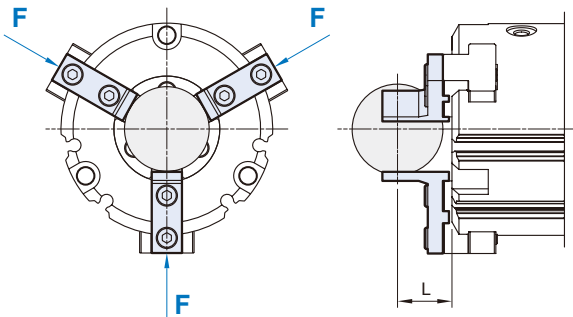

Agarre externo

Fuerza de agarre externa

MCHG2-16

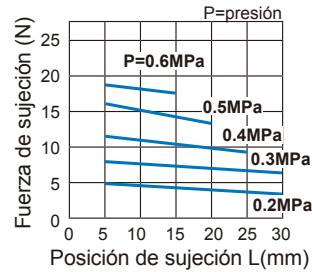

MCHG2-50

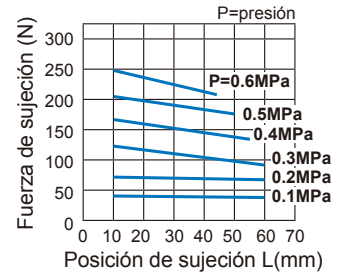

MCHG2-20

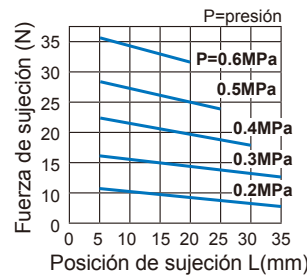

MCHG2-63

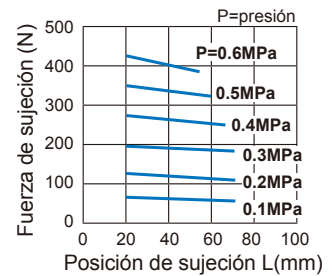

MCHG2-25

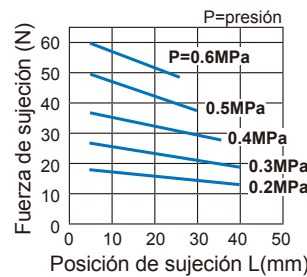

MCHG2-80

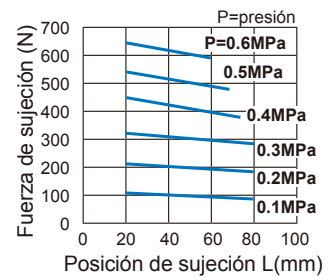

MCHG2-32

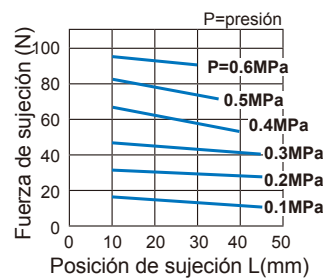

MCHG2-100

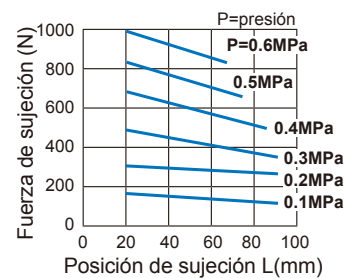

MCHG2-40

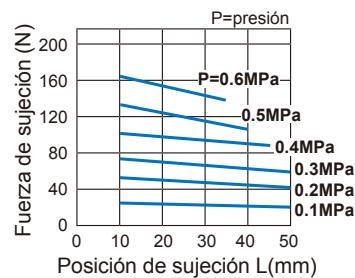

MCHG2-125

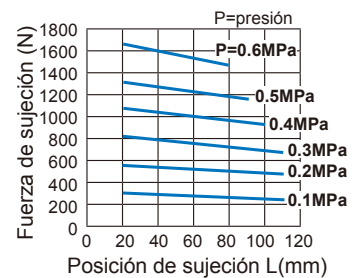

Fuerza de agarre efectiva

* Para la selección de dedos consulte la pág. 3-2.

Indicador de la fuerza de agarre efectiva.

La fuerza efectiva de agarre que se muestra en los gráficos a la derecha se expresa como F, que es el empuje de un dedo cuando los tres dedos y los adaptadores están en pleno contacto con la pieza de trabajo, como se muestra en la figura a continuación.

1N=0.102 kgf
1MPa=10.2 kgf/cm²

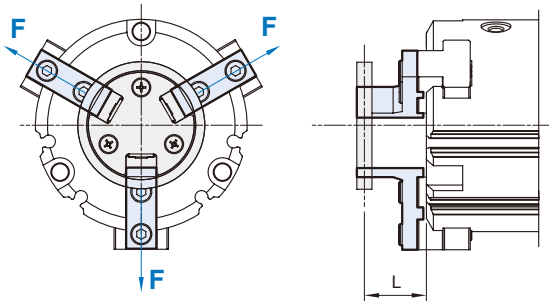

Agarre interno

Fuerza de agarre interna

MCHG2-16

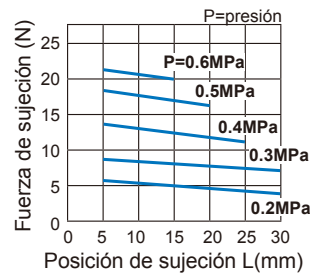

MCHG2-50

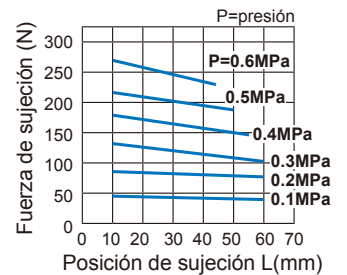

MCHG2-20

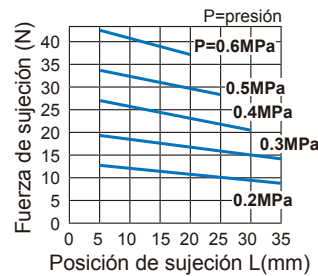

MCHG2-63

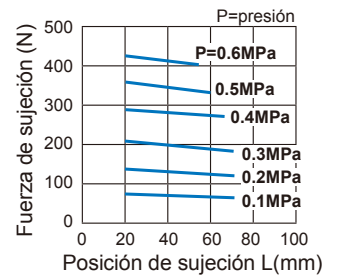

MCHG2-25

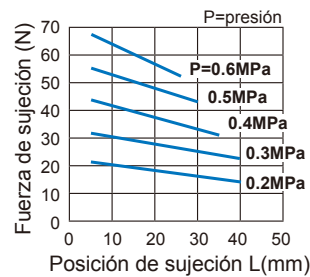

MCHG2-80

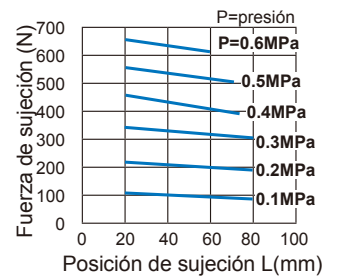

MCHG2-32

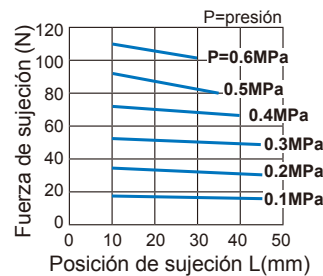

MCHG2-100

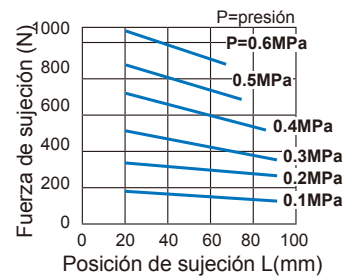

MCHG2-40

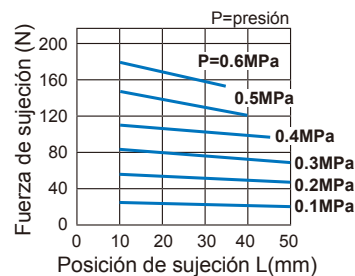

MCHG2-125

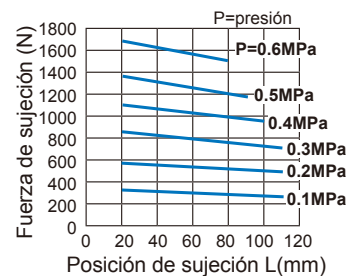

PINZA PARALELA (3-Dedos)

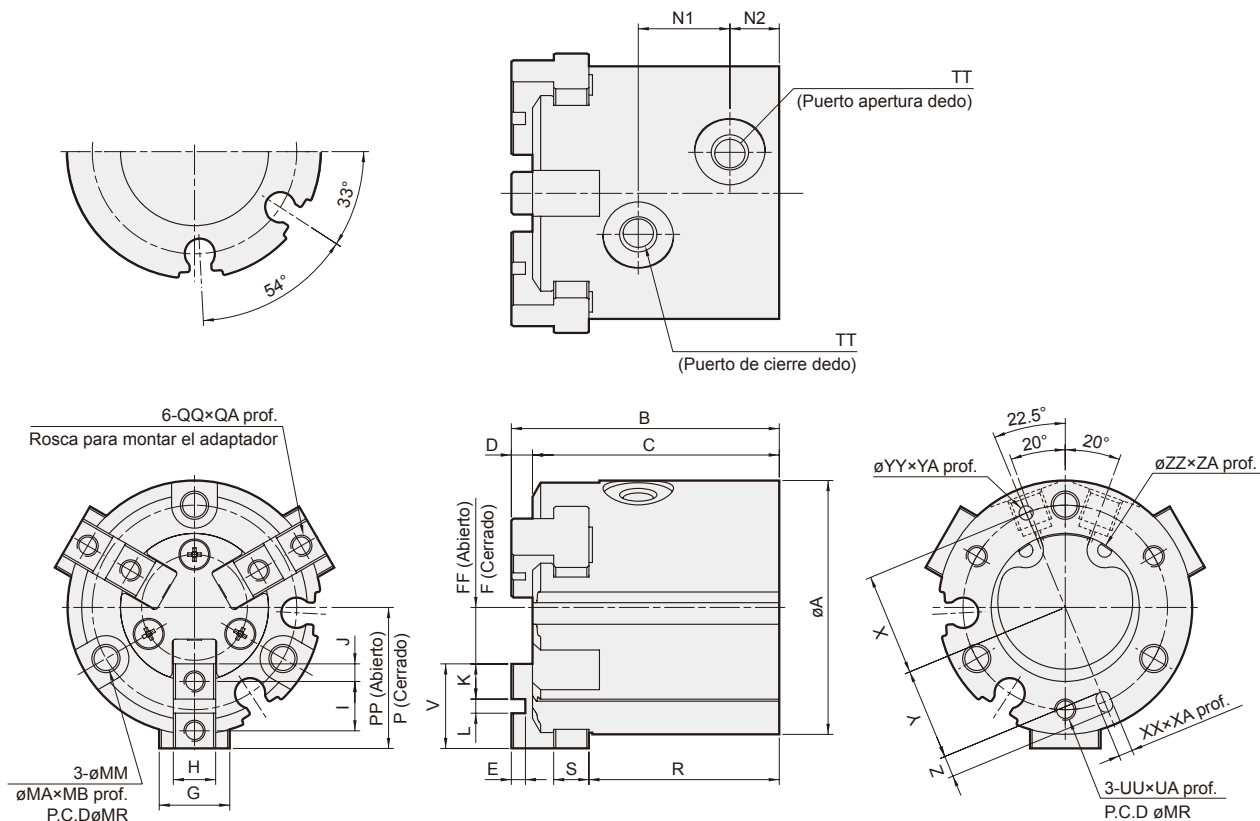

Código D.I. Tubo	A	B	C	D	E	F	FF	G	H	I	J	K	L	MA	MB	MM	MR	N1	N2	P	PP	QA	QQ	R	S	TT
16	30	35	32	3	2	5	7	8	5h9 ⁺⁰ _{-0.030}	6	2	4	2H9 ^{+0.025} ₀	6.5	8	3.4	25	11	7	15	17	5	M3x0.5	25	4	M3x0.5
20	36	38	35	3	2	6	8	10	6h9 ⁺⁰ _{-0.030}	7	2.5	5	2H9 ^{+0.025} ₀	6.5	9.5	3.4	29	13	7	18	20	6	M3x0.5	27	5	M5x0.8
25	42	40	37	3	2	7	10	12	6h9 ⁺⁰ _{-0.030}	8	3	6	2H9 ^{+0.025} ₀	8	10	4.5	34	15	7	21	24	6	M3x0.5	28	5	M5x0.8

Código D.I. Tubo	UA	UU	V	X	XA	XX	Y	YA	YY	Z	ZA	ZZ
16	4.5	M3x0.5	10	12.5	2	2H9 ^{+0.025} ₀	11	2	2H9 ^{+0.025} ₀	3	1.5	17H9 ^{+0.043} ₀
20	6	M3x0.5	12	14.5	2	2H9 ^{+0.025} ₀	13	2	2H9 ^{+0.025} ₀	3	1.5	21H9 ^{+0.052} ₀
25	6	M4x0.7	14	17	3	3H9 ^{+0.025} ₀	14.5	3	3H9 ^{+0.025} ₀	5	1.5	26H9 ^{+0.052} ₀

PINZA PARALELA (3-Dedos)

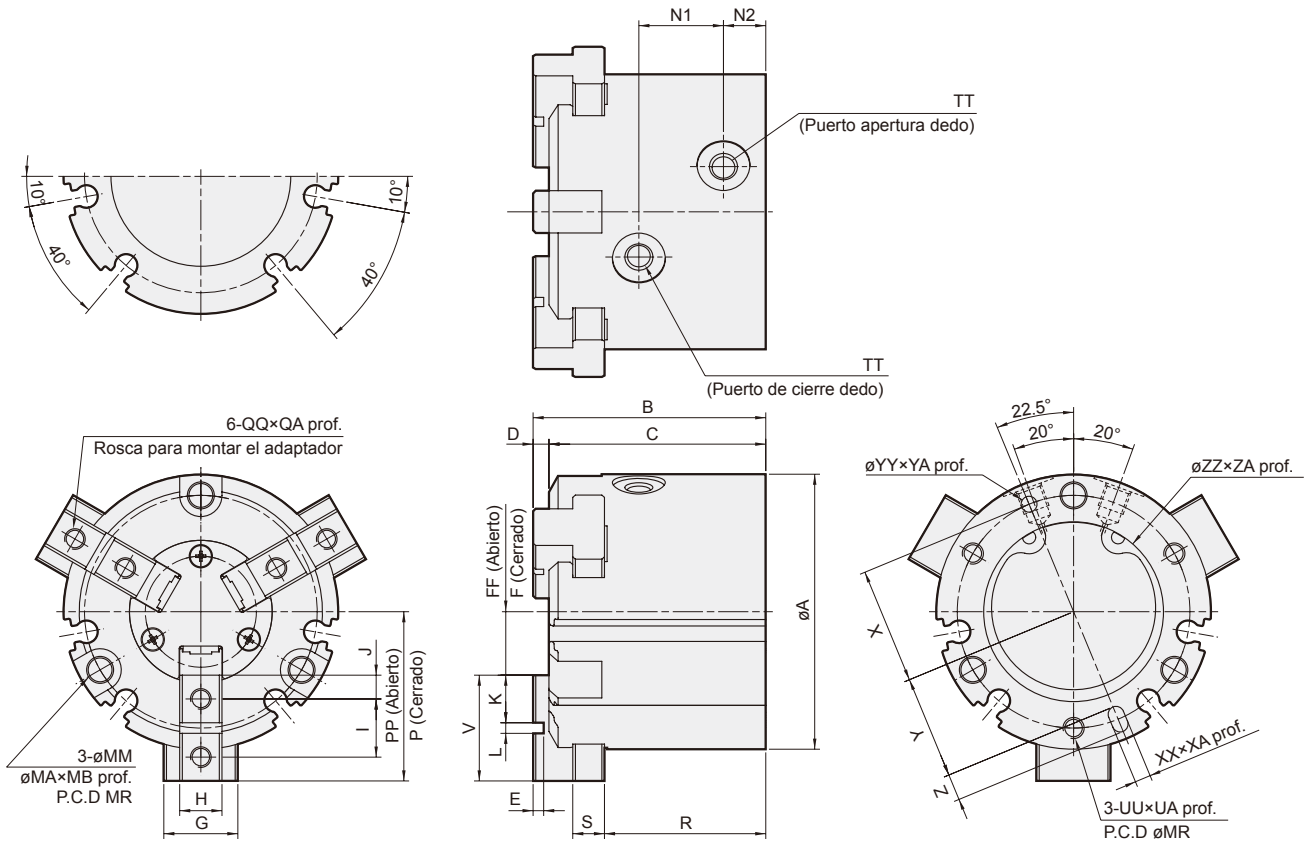

Código D.I. Tubo	A	B	C	D	E	F	FF	G	H	I	J	K	L	MA	MB	MM	MR	N1	N2	P	PP	QA	QQ
32	52	44	41	3	2	8	12	14	8h9 ⁺⁰ _{-0.036}	11	4.5	9	2H9 ^{+0.025} ₋₀	8	9	4.5	44	16	8	28	32	8	M4×0.7
40	62	47	44	3	2	10	14	16	8h9 ⁺⁰ _{-0.036}	12	4.5	9	3H9 ^{+0.025} ₋₀	9.5	9	5.5	53	17	9	31	35	8	M4×0.7
50	70	55	52	3	2	11	17	18	10h9 ⁺⁰ _{-0.036}	14	5	10	4H9 ^{+0.030} ₋₀	9.5	12	5.5	62	20	9	35	41	10	M5×0.8
63	86	66	62	4	3	15	23	24	12h9 ⁺⁰ _{-0.043}	17	5.5	11	6H9 ^{+0.030} ₋₀	11	14	6.6	76	22	12	43	51	10	M5×0.8
80	106	82	77	5	4	21.5	31.5	28	14h9 ⁺⁰ _{-0.043}	20	6	12	8H9 ^{+0.036} ₋₀	11	19	6.6	95	27	13.5	53.5	63.5	12	M6×1.0
100	134	96	90	6	4	28	40	34	18h9 ⁺⁰ _{-0.043}	23	7.5	15	8H9 ^{+0.036} ₋₀	14	21	9	118	30.6	18	66	78	16	M8×1.25
125	166	122	114	8	6	30	46	40	22h9 ⁺⁰ _{-0.052}	31	10.5	21	10H9 ^{+0.036} ₋₀	17.5	34	11	148	38	23.5	82	98	20	M10×1.5

Código D.I. Tubo	R	S	TT	UU	UA	V	X	XA	XX	Y	YY	YA	Z	ZA	ZZ
32	30.5	6	M5×0.8	M4×0.7	6	20	22	3	3H9 ^{+0.025} ₋₀	19.5	3H9 ^{+0.025} ₋₀	3	5	2	34H9 ^{+0.062} ₋₀
40	32	7	M5×0.8	M5×0.8	7.5	21	26.5	4	4H9 ^{+0.030} ₋₀	23.5	4H9 ^{+0.030} ₋₀	4	6	2	42H9 ^{+0.062} ₋₀
50	37.5	9	M5×0.8	M5×0.8	10	24	31	4	4H9 ^{+0.030} ₋₀	28	4H9 ^{+0.030} ₋₀	4	6	2	52H9 ^{+0.074} ₋₀
63	44	11	M5×0.8	M6×1.0	9	28	38	5	5H9 ^{+0.030} ₋₀	34.5	5H9 ^{+0.030} ₋₀	5	7	2.5	65H9 ^{+0.074} ₋₀
80	56	12	Rc1/8	M6×1.0	12	32	47.5	6	6H9 ^{+0.030} ₋₀	43.5	6H9 ^{+0.030} ₋₀	6	8	3	82H9 ^{+0.087} ₋₀
100	63	15	Rc1/4	M8×1.25	16	38	59	6	8H9 ^{+0.036} ₋₀	54	8H9 ^{+0.036} ₋₀	6	10	4	102H9 ^{+0.087} ₋₀
125	84	18	Rc3/8	M10×1.5	20	52	74	8	10H9 ^{+0.036} ₋₀	68	10H9 ^{+0.036} ₋₀	8	12	6	130H9 ^{+0.100} ₋₀